

24 Foot Commercial Restroom Trailer

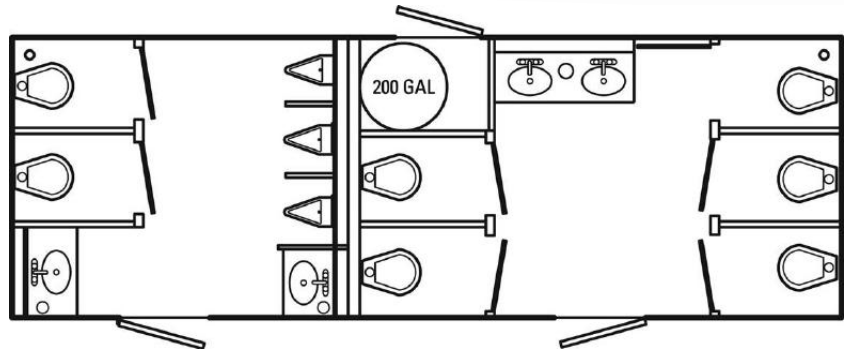

gotüimpress

Our 24 Foot Commercial Restroom Trailer is spacious and durable yet attractive and comfortable, built to accommodate most commercial and construction job sites. This trailer is equipped with two private entrances, seven private stalls and three individual urinals. You and your employees will appreciate the modern amenities this trailer has to offer including waterless urinals, stainless steel sinks, air conditioning/heating, USB port, Sony Bluetooth Audio System, entryway lighting and much more!

Features:

- 7 Private Stalls
- 3 Individual Urinals
- 2 Entrances
- Foot Flushing Toilet Bowls
- White Waterless Urinals
- Stainless Steel Sinks
- Modern Countertops
- Soap Dispensers
- Dual Paper Towel Dispensers
- Air Conditioning/Heating
- Air Vents with Fans
- Interior LED Lighting
- Exterior LED Entryway Lighting

- USB Port & Sony Bluetooth Audio System
- AM/FM Stereo with CD Player

Specifications:

- Height: 11' 6"
- Length: 24' (29' w/tongue)
- Width: 8' 3"
- Water Source: Hose Hook-up or 200 gal Self Contained
- Waste Holding Tank Capacity: 1000 gal
- Withstands Temperatures to 0°F